

Square Tree Stump Table Instructions

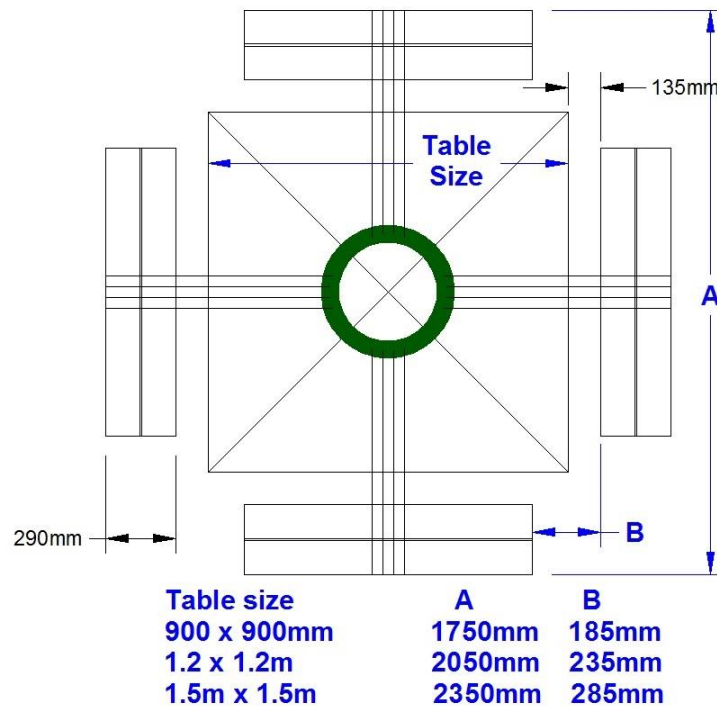

1. Level the ground as much as possible. Work out the square boundary of the table based on the size purchased and mark the ground.



2. Place the seat on the in the correct position. The seats will be protruding out beyond the boundary markers and the braces will need to be trimmed to get the seats closer to the stump.



3. Trim back the tree tie braces so that the timber fits relatively snug against the tree and the outer edge of the seat lines up up with the outer boundary markers.
4. Once all 4 seats have been trimmed back and in position check for squareness and then attach each brace to the tree.



5. To attach a brace pre drill a 6mm hole diagonally through the brace making sure you are well away from the edge of the brace front edge. Use the 8x100mm Galvanised batten screws provided.
6. All four seats should now be fully attached and lined up with the outside markers
7. Seat heights should be 460mm above ground level
8. The final table top height should be 760mm above ground. The table thickness including the metal bracket is 50mm. Therefore the stump should be cut level and to a height of 710mm above ground level. (250mm above the seat heights, or 295mm above the seat braces)



9. Mark several spots around the stump at the cutting height and finally cut the stump. (If you undercut the stump slightly you will need to place packers between the stump and metal bracket to compensate.)



10. Place the metal bracket on the stump and ensure it is lined up to the centre of the table area.
(If the stump has a lean to it this means the bracket will be off centre on the stump)
11. The metal bracket arms should run diagonally corner to corner of the table.
12. Mark the bracket position on the stump.



13. Using a chainsaw cut the lines to a depth of 50mm or use a circular saw and make several cuts to widen the trench and ensure the bracket can sit into the slots
14. Place the bracket into position and level it by using packers if the stump is not perfectly level.
15. Screw the bracket into the stump ensuring the screws go in diagonally and bite well into the timber. Use the 4 x 40mm Hex Tek Screws provided.



16. Place the table top onto the bracket and make any last minute adjustments before screwing the table top onto the metal bracket from underneath. Use the 4 x 40mm Hex Tek screws provided Pre drill the holes with a 4mm drill.

